



ITT

Let there be light! - Introduction to USEPA's UV Design Guidance Manual

March 2010

Matthias Boeker

Disinfection Market Manager

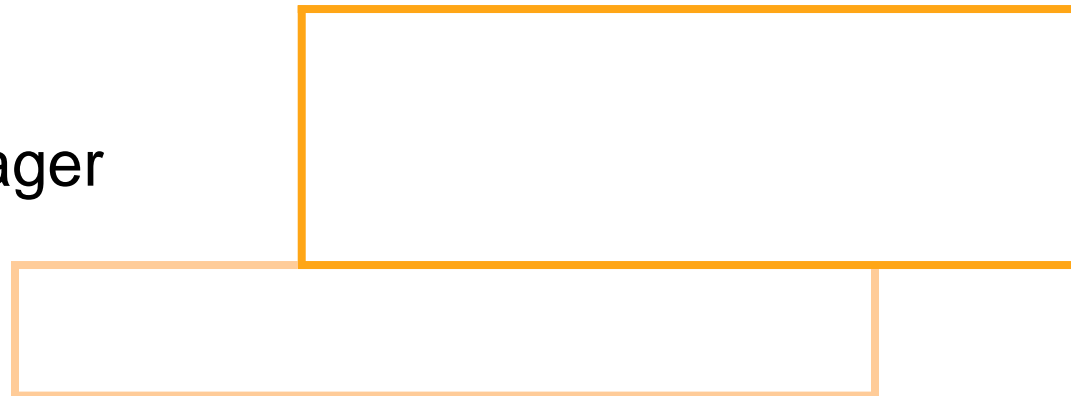

Engineered for life

Water & Wastewater

UVDGM 2006 – Published in November 2006



ULTRAVIOLET DISINFECTION GUIDANCE MANUAL FOR THE FINAL LONG TERM 2 ENHANCED SURFACE WATER TREATMENT RULE

Office of Water (4601)
EPA 815-R-06-007
November 2006

<http://www.epa.gov/safewater/disinfection/lt2/compliance.html>



Let there be light! - Introduction to USEPA's UVDGM

March 2010



UVDGM 2006 – Objectives

- Provide **PWSs (Public Water Supplies) and designers** with technical information and guidance on selecting, designing, and operating UV installations and complying with the UV disinfection related requirements in the LT2ESWTR.
- Provide **states** with guidance and the necessary tools to assess UV installations during the design, start-up, and routine operation phases.
- Provide **manufacturers** with testing and performance standards for UV reactors and components intended for treating drinking water.

UVDGM 2006 – Very Good Collection of UV Knowledge

- Glossary
- History of UV disinfection
- Definition of UVT
- Microbial Repair
- UV Lamps
- Lamps Start-up
- Fouling Potential

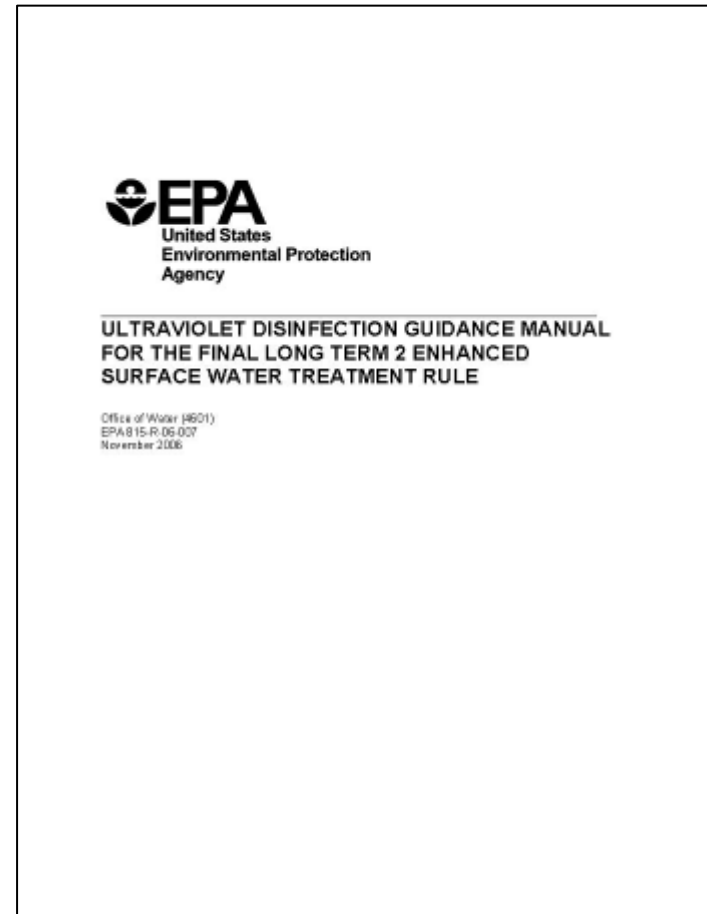

Table 1.1. Summary of Microbial and DBP Rules

Surface Water Treatment Rules – Minimum Treatment Requirements ¹				
Regulation	Giardia	Virus	Cryptosporidium	
SWTR	3-log removal and/or inactivation	4-log removal and/or inactivation	Not addressed	
IESWTR and LT1ESWTR	No change from SWTR		2-log removal	
LT2ESWTR	No change from SWTR		0- to 2.5-log additional treatment for filtered systems ²	
			2- or 3-log inactivation for unfiltered systems ²	
DBP Rules – MCLs Based on Running Annual Averages (RAAs) or Locational RAAs (LRAAs)				
Regulation	Total Trihalomethanes (TTHM) (µg/L) ³	Five Haloacetic Acids (HAA5) (µg/L) ³	Bromate (µg/L) ³	Chlorite (µg/L) ³
Stage 1 DBPR	80 as RAA	60 as RAA	10	1000
Stage 2 DBPR ⁴	80 as LRAA	60 as LRAA	No change from Stage 1	

¹ The term “log” means the order of magnitude reduction in concentration; e.g., 2-log removal equals a 99% reduction, 3-log removal equals a 99.9% reduction, and 4-log removal equals a 99.99-percent reduction.

² Specific requirements for each plant depend on source water monitoring results and current treatment practices (40 CFR 141.710 – 141.712).

³ micrograms/liter (µg/L)

⁴ Monitoring locations for LRAAs are identified from the Initial Distribution System Evaluation.

Table 1.2. Bin Requirements for Filtered PWSs

Cryptosporidium Concentration (oocysts/L)	Bin Classification	And if the following filtration treatment is operating in full compliance with existing regulations, then the additional treatment requirements are ² ...			
		Conventional Filtration Treatment (includes softening)	Direct Filtration	Slow Sand or Diatomaceous Earth Filtration	Alternative Filtration Technologies
< 0.075	1	No additional treatment	No additional treatment	No additional treatment	No additional treatment
≥ 0.075 and < 1.0	2	1 log treatment ³	1.5 log treatment ³	1 log treatment ³	As determined by the state ^{3,5}
≥ 1.0 and < 3.0	3	2 log treatment ⁴	2.5 log treatment ⁴	2 log treatment ⁴	As determined by the state ^{4,6}
≥ 3.0	4	2.5 log treatment ⁴	3 log treatment ⁴	2.5 log treatment ⁴	As determined by the state ^{4,7}

¹ From 40 CFR 141.711

² Additional treatment requirements reflect a *Cryptosporidium* removal credit of 3 log for a conventional, slow sand, or diatomaceous earth filtration, and a 2.5-log credit for direct filtration plants.

³ PWSs may use any technology or combination of technologies from the microbial toolbox.

⁴ PWSs must achieve at least 1 log of the required treatment using ozone, chlorine dioxide, UV light, membranes, bag/cartridge filters, or bank filtration.

⁵ Total *Cryptosporidium* treatment must be at least 4.0 log.

⁶ Total *Cryptosporidium* treatment must be at least 5.0 log.

⁷ Total *Cryptosporidium* treatment must be at least 5.5 log.

Table 1.3. Requirements for Unfiltered PWSs

Table 1.3. Requirements for Unfiltered PWSs

Average <i>Cryptosporidium</i> Concentration (oocysts/L)	Additional <i>Cryptosporidium</i> Inactivation Requirements
≤ 0.01	2 log ¹
> 0.01	3 log ¹

¹ Overall disinfection requirements must be met with a minimum of two disinfectants [40 CFR 141.712(d)].

Unfiltered PWSs are exempt from *Cryptosporidium* monitoring if the PWS provides, or will provide, a total of at least 3-log *Cryptosporidium* inactivation—the maximum treatment required by the LT2ESWTR for unfiltered systems [40 CFR 141.701(d)]—by the treatment compliance date. (See Figure 1.1.) Installing a UV disinfection system that is validated for the appropriate inactivation credit can achieve this objective.

Required Log Reduction for Cryptosporidium

Depends on:

- Pre-treatment process
 - filtered / unfiltered
 - type of filtration and related removal credit:
 - 3 log for a conventional, slow sand, or diatomaceous earth filtration
 - 2.5-log credit for direct filtration plants
- Cryptosporidium Concentration (oocysts/L) in raw water

Multi-barrier Concept

Removal credits for various treatment technologies:

- Ozone
- Chlorine dioxide
- UV light
- Membranes
- Bag/cartridge filters
- Bank filtration

=> UV dose requirements are site-specific

Multi-barrier Concept: UV and Chlorine Dose Rates

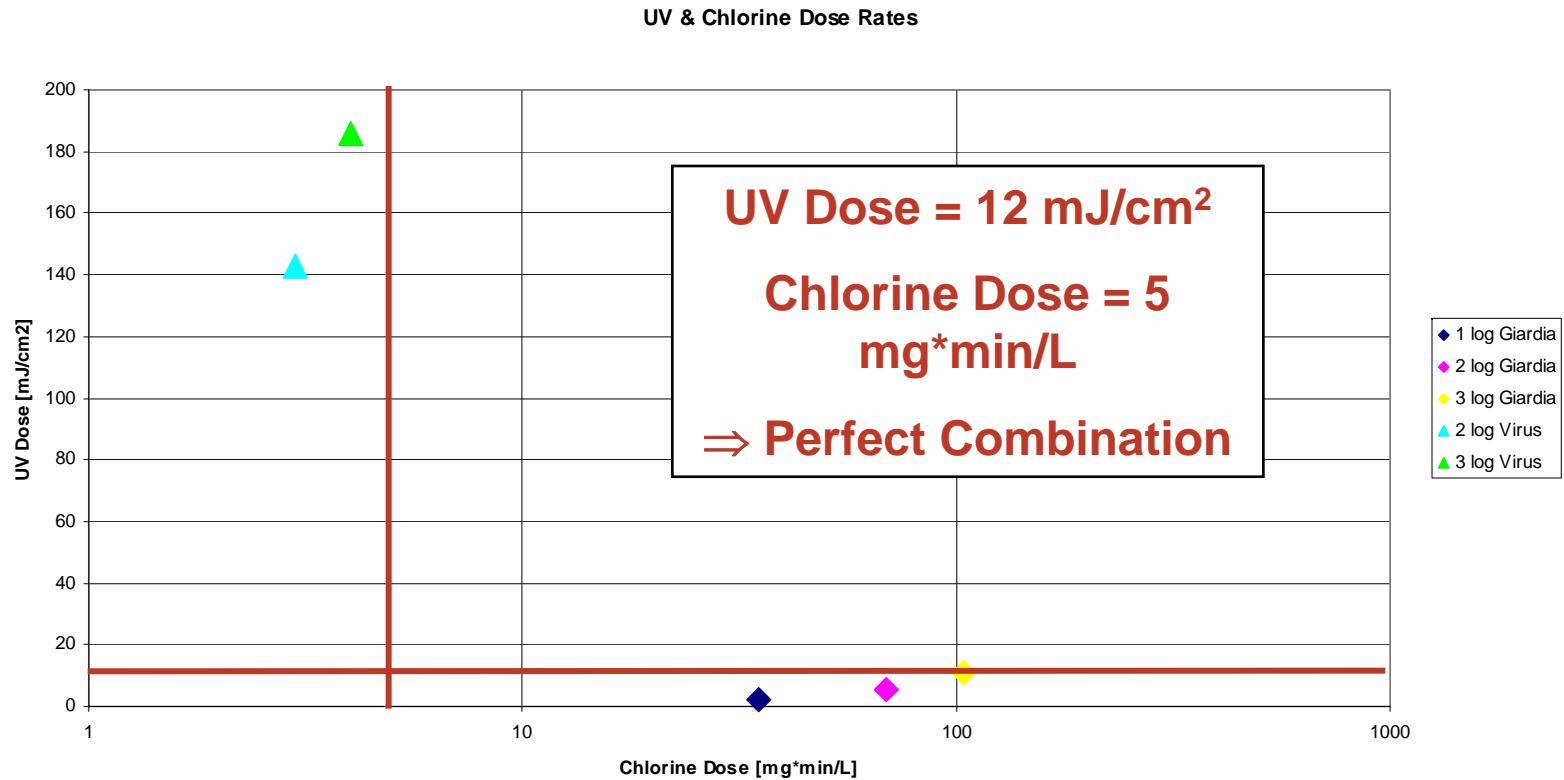

CT for chlorine: T = 10 °C; pH 6 – 9; free chlorine residual of 0.2 – 0.5 mg/l

Table 1.4. UV Dose Requirements (mJ/cm²)

Table 1.4. UV Dose Requirements – millijoules per centimeter squared (mJ/cm²)¹

Target Pathogens	Log Inactivation							
	0.5	1.0	1.5	2.0	2.5	3.0	3.5	4.0
<i>Cryptosporidium</i>	1.6	2.5	3.9	5.8	8.5	12	15	22
<i>Giardia</i>	1.5	2.1	3.0	5.2	7.7	11	15	22
Virus	39	58	79	100	121	143	163	186

¹ 40 CFR 141.720(d)(1)

Validated UV Reactors ONLY

Figure 1.1. LT2ESWTR Compliance Timeline for Initial Source Water Monitoring and Treatment Installation

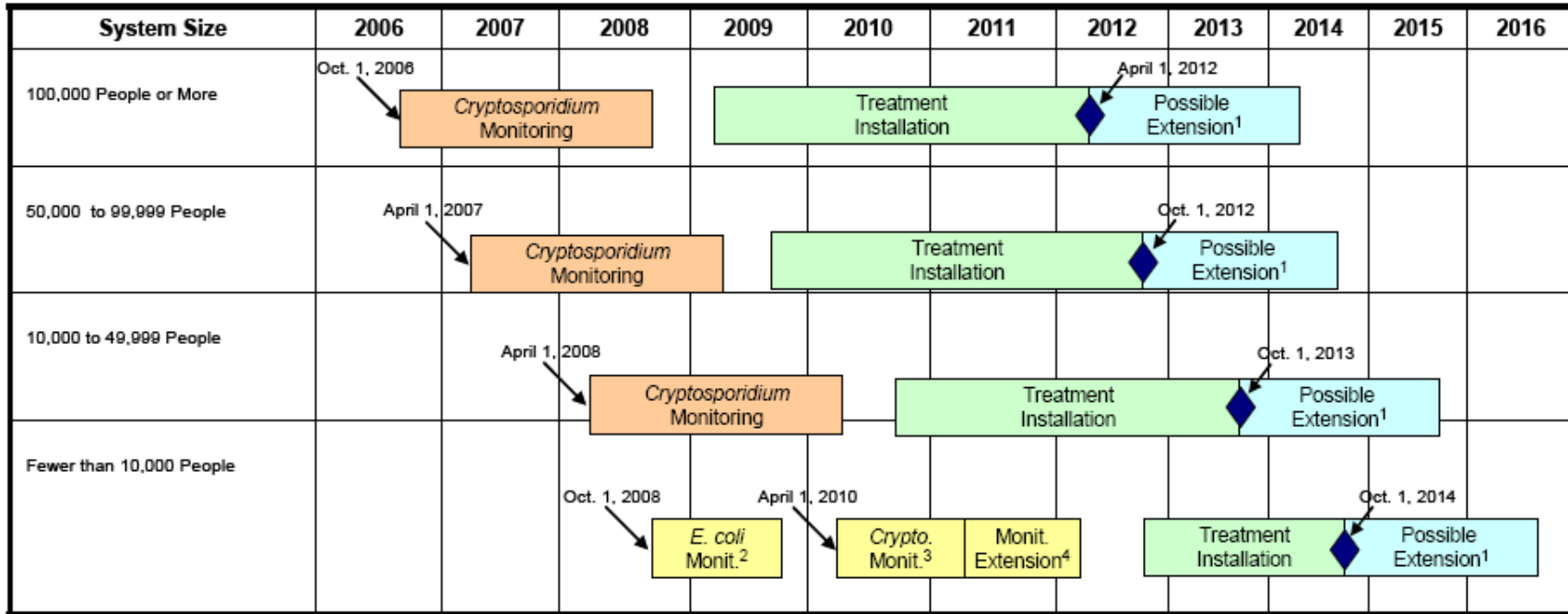

◆ Regulatory Compliance Date

- ¹ Two-year extension may be granted at the discretion of the state for systems requiring capital improvements.
- ² *E. coli* monitoring applies only to filtered systems or unfiltered systems that are required to install filtration.
- ³ *Cryptosporidium* monitoring for small systems is necessary only if *E. coli* monitoring indicates an annual mean concentration greater than 50 *E. coli* per 100 mL.
- ⁴ Systems serving fewer than 10,000 people may monitor *Cryptosporidium* either by collecting two samples per month for one year or one sample per month for two years.

Table 5.1. Summary of LT2ESWTR Validation Requirements

Table 5.1. Summary of LT2ESWTR Validation Requirements

Requirement	Conditions	Citation
<i>Validated operating conditions must include</i>	<ul style="list-style-type: none"> • Flow rate • UV intensity as measured by a UV sensor • UV lamp status 	40 CFR 141.720 (d)(2)
<i>Validation testing must include ¹</i>	<ul style="list-style-type: none"> • Full-scale testing of a reactor that conforms uniformly to the UV reactors used by the water system • Inactivation of a test microorganism whose dose-response characteristics have been quantified with a low-pressure mercury vapor lamp 	40 CFR 141.720 (d)(2)(ii)
<i>Validation testing must account for</i>	<ul style="list-style-type: none"> • UV absorbance of the water • Lamp fouling and aging • Measurement uncertainty of on-line sensors • UV dose distributions arising from the velocity profiles through the reactor • Failure of UV lamps or other critical components • Inlet and outlet piping or channel configurations of the UV reactor 	40 CFR 141.720 (d)(2)(i)

¹ The state may approve an alternative approach to validation testing.

Overview of Recommended Validation Protocol

Step 1a

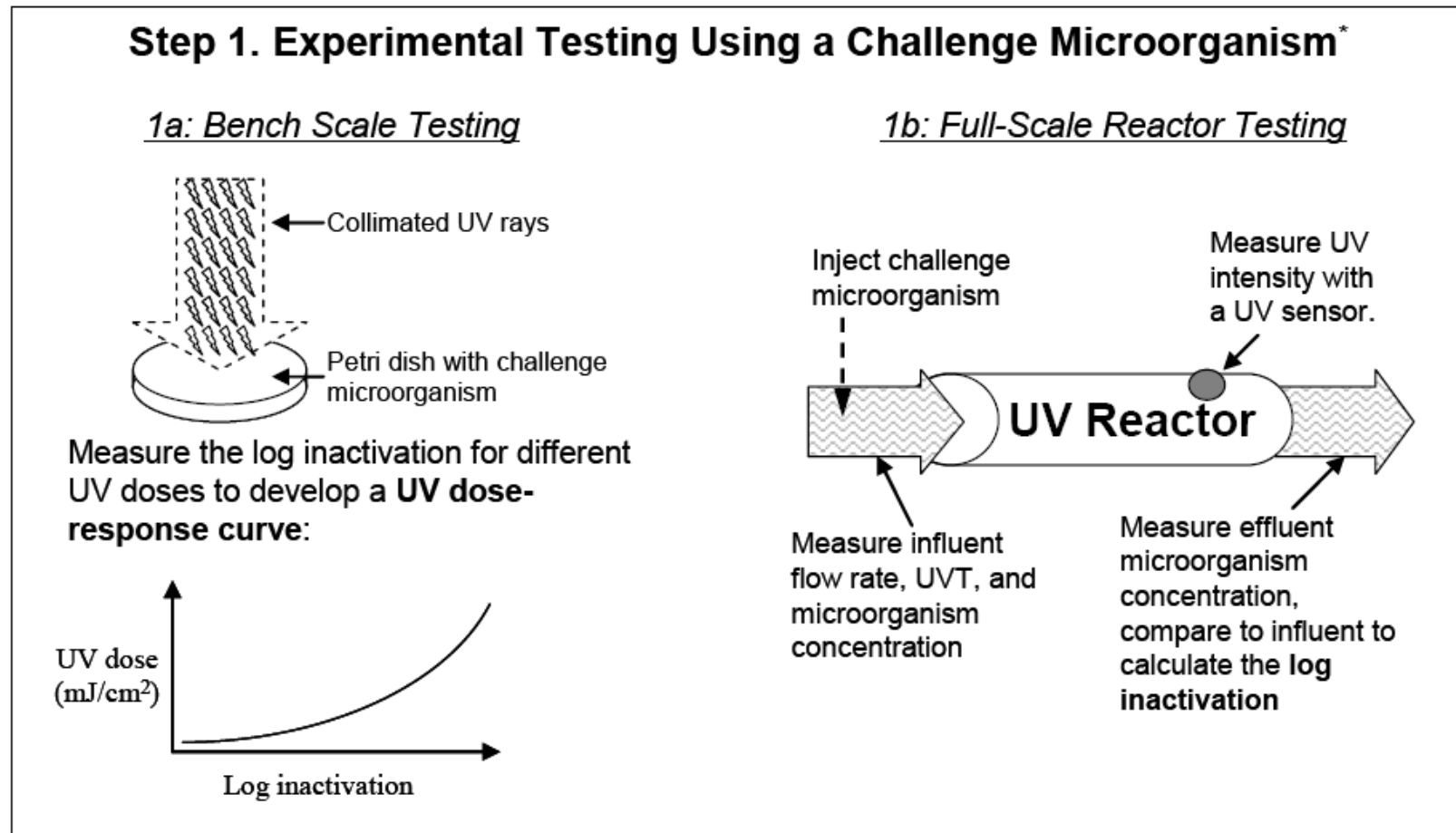

UV Dose Measurement Device

UV Dose

=

Time

x

Intensity

This only works for static systems with a uniform intensity distribution: the collimated beam device.

The Collimated Beam Device

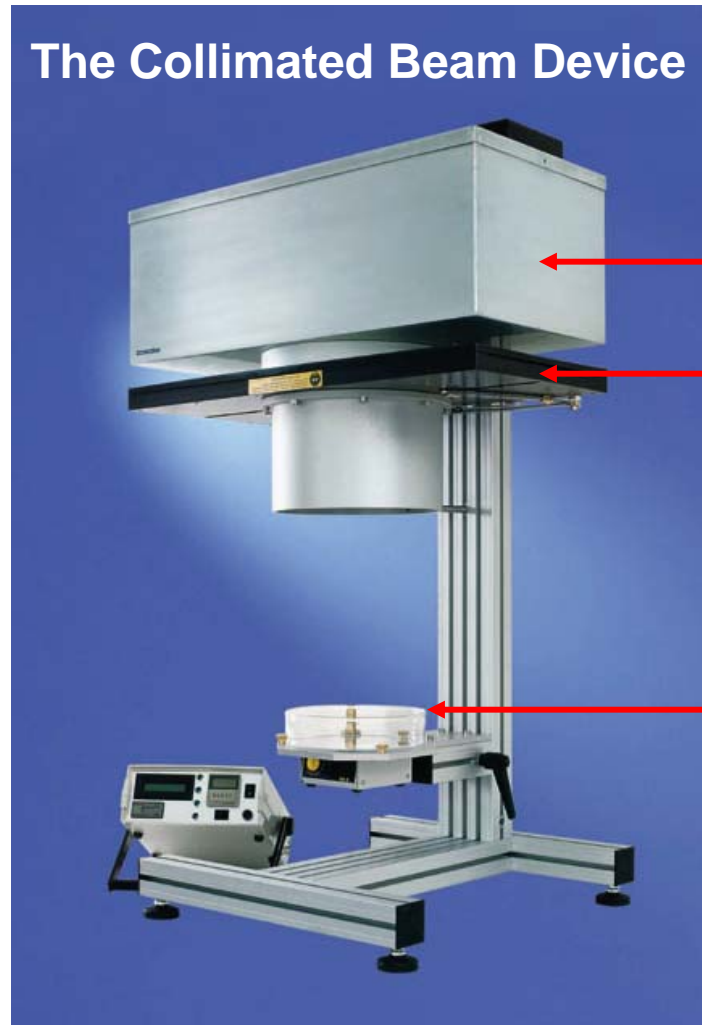

UV lamps

Shutter
→ controlled /
uniform retention
time

Surface of
sample
→ measured /
uniform intensity

Overview of Recommended Validation Protocol

Step 1b

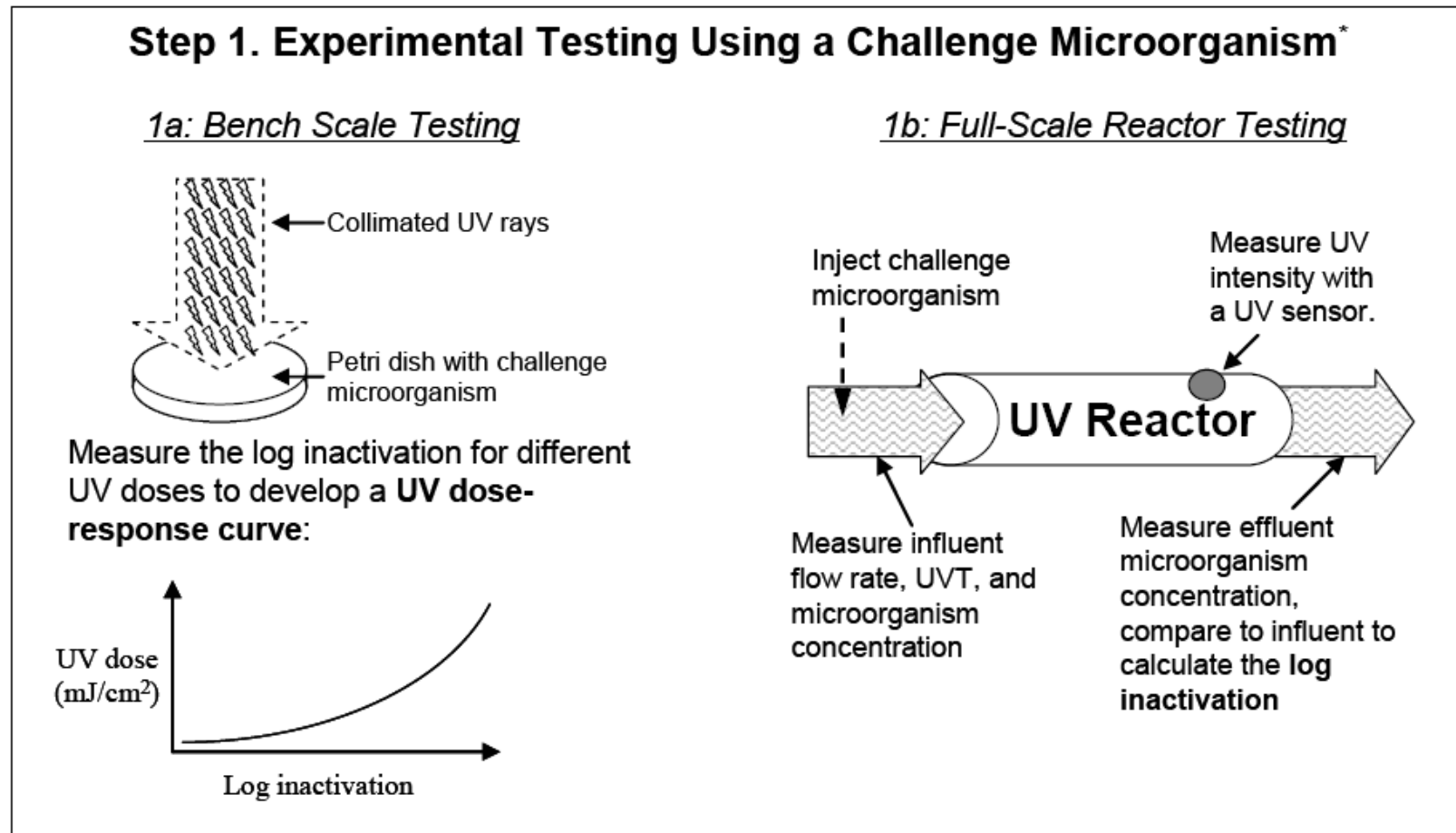

Overview of Recommended Validation Protocol Step 2

Step 2. Determine the Reduction Equivalent Dose (RED)

Input the log inactivation from Step 1b into the dose-response curve from Step 1a to estimate RED.

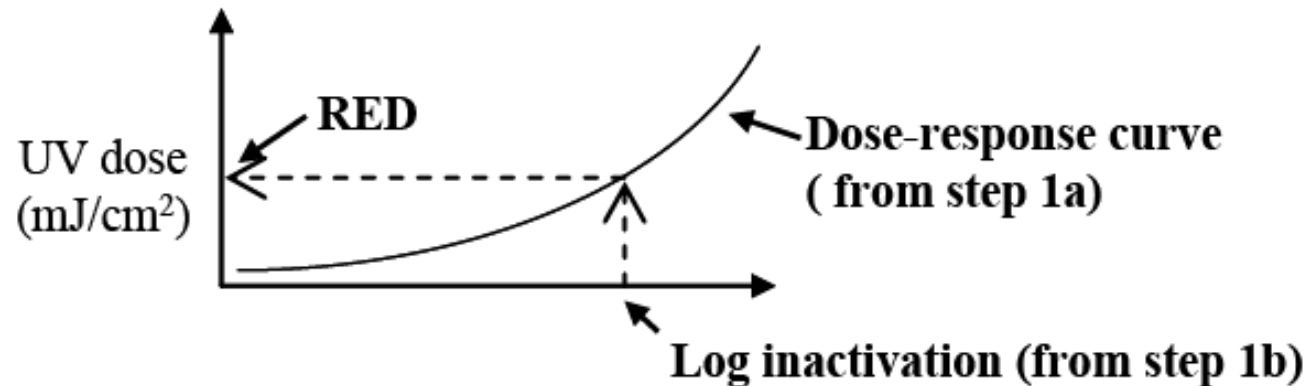

Overview of Recommended Validation Protocol Step 3



Step 3. Adjust for Uncertainty to Calculate the Validated Dose

$$\textit{Validated Dose} = \textit{RED} / \textit{VF}$$

Where VF = Validation Factor that accounts for biases and experimental uncertainty.

Validation Factor Analysis

$$\text{Validated Dose} = RED / VF$$

where:

RED = Reduction Equivalent Dose

VF = Validation Factor that accounts for biases and experimental uncertainty

$$VF = B_{RED} * (1 + U_{VAL} / 100)$$

where:

B_{RED} = RED Bias Factor

U_{VAL} = Uncertainty of Validation (%)

B_{RED} = RED Bias Factor

- The RED bias is a correction factor that accounts for the difference between the UV sensitivity of the target pathogen and the UV sensitivity of the challenge microorganism.
- Tables are presented in Appendix G of the UVDGM where B_{RED} can be looked up as a function of
 - the target pathogen log inactivation,
 - the UV sensitivity of the validation microorganism, and
 - the ambient UV transmittance (UVT) of the water.

Table 5.2. UV Sensitivity of Challenge Microorganisms

Table 5.2. UV Sensitivity of Challenge Microorganisms

Microorganism	Reported Delivered UV Dose (mJ/cm ²) to Achieve Indicated Log Inactivation				Reference
	1-log	2-log	3-log	4-log	
Bacillus subtilis	28	39	50	62	Sommer et al. 1998
MS2 phage	16	34	52	71	Wilson et al. 1992
Qβ phage	10.9	22.5	34.6	47.6	Mackey et al. 2006
PRD-1 phage	9.9	17	24	30	Meng and Gerba 1996
B40-8 phage	12	18	23	28	Sommer et al. 1998
φx174 phage	2.2	5.3	7.3	11	Sommer et al. 1998
<i>E. coli</i>	3.0	4.8	6.7	8.4	Chang et al. 1985
T7	3.6	7.5	11.8	16.6	Mackey et al. 2006
T1	~5	~10	~15	~20	Wright 2006

Deviating dose-response characteristics of test and target microorganisms

Table 1.4. UV Dose Requirements – millijoules per centimeter squared (mJ/cm²)¹

Target Pathogens	Log Inactivation							
	0.5	1.0	1.5	2.0	2.5	3.0	3.5	4.0
<i>Cryptosporidium</i>	1.6	2.5	3.9	5.8	8.5	12	15	22
<i>Giardia</i>	1.5	2.1	3.0	5.2	7.7	11	15	22
Virus	39	58	79	100	121	143	163	186

¹ 40 CFR 141.720(d)(1)

Table 5.2. UV Sensitivity of Challenge Microorganisms

Microorganism	Reported Delivered UV Dose (mJ/cm ²) to Achieve Indicated Log Inactivation				Reference
	1-log	2-log	3-log	4-log	
Bacillus subtilis	28	39	50	62	Sommer et al. 1998
MS2 phage	16	34	52	71	Wilson et al. 1992
Qβ phage	10.9	22.5	34.6	47.6	Mackey et al. 2006
PRD-1 phage	9.9	17	24	30	Meng and Gerba 1996
B40-8 phage	12	18	23	28	Sommer et al. 1998
φx174 phage	2.2	5.3	7.3	11	Sommer et al. 1998
<i>E. coli</i>	3.0	4.8	6.7	8.4	Chang et al. 1985
T7	3.6	7.5	11.8	16.6	Mackey et al. 2006
T1	~5	~10	~15	~20	Wright 2006

Deviating dose-response characteristics of test and target microorganisms – Graph

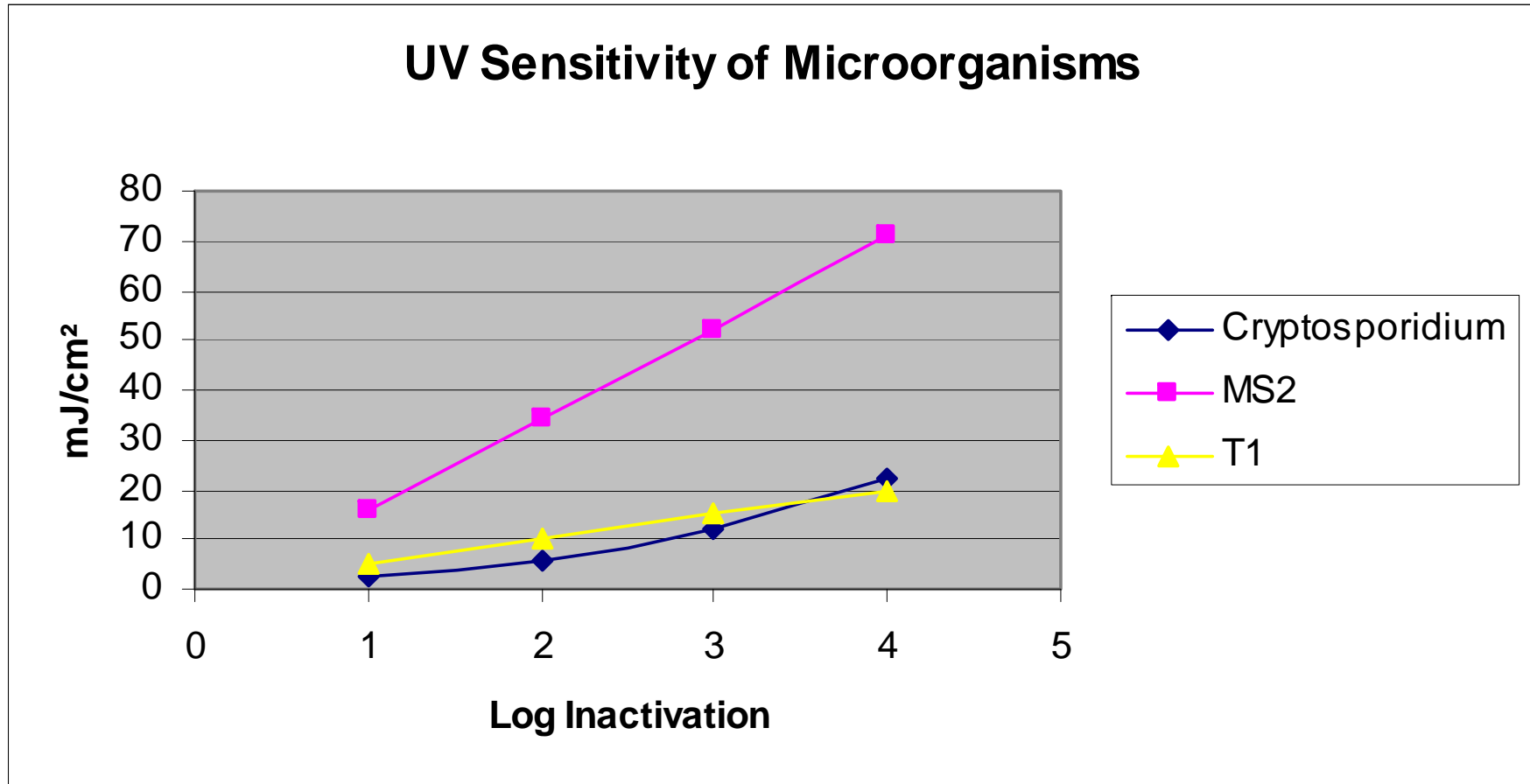

Table G.3. RED Bias Values for 3.0-log Cryptosporidium Inactivation Credit as a Function of UVT and UV Challenge Microorganism Sensitivity

<i>Cryptosporidium</i> log inactivation credit		3.0						
Required UV dose (mJ/cm ²)		12						
<i>Cryptosporidium</i> UV sensitivity (mJ/cm ² /log I)		4.0						
UVT (%)		≥ 98	≥ 95	≥ 90	≥ 85	≥ 80	≥ 75	≥ 65
Challenge UV sensitivity (mJ/cm ² /log I)		RED Bias						
Lower	Upper							
0	≤ 2	1.00	1.00	1.00	1.00	1.00	1.00	1.00
> 2	≤ 4	1.00	1.00	1.00	1.00	1.00	1.00	1.00
> 4	≤ 6	1.05	1.10	1.15	1.17	1.19	1.21	1.23
> 6	≤ 8	1.09	1.18	1.27	1.32	1.36	1.40	1.45
> 8	≤ 10	1.12	1.23	1.38	1.47	1.52	1.58	1.66
> 10	≤ 12	1.14	1.27	1.47	1.59	1.68	1.75	1.86
> 12	≤ 14	1.16	1.31	1.55	1.71	1.82	1.92	2.06
> 14	≤ 16	1.17	1.33	1.62	1.82	1.96	2.08	2.26
> 16	≤ 18	1.18	1.36	1.68	1.92	2.09	2.24	2.45
> 18	≤ 20	1.19	1.38	1.73	2.01	2.22	2.39	2.65
> 20	≤ 22	1.20	1.39	1.78	2.10	2.34	2.54	2.84
> 22	≤ 24	1.21	1.41	1.82	2.18	2.45	2.69	3.03
> 24	≤ 26	1.22	1.42	1.85	2.25	2.56	2.83	3.21
> 26	≤ 28	1.22	1.43	1.89	2.32	2.66	2.96	3.40
> 28	≤ 30	1.23	1.44	1.92	2.38	2.76	3.10	3.58
> 30	≤ 32	1.23	1.45	1.95	2.44	2.86	3.23	3.76
> 32	≤ 34	1.24	1.46	1.97	2.50	2.95	3.35	3.94

T1

MS2

U_{VAL} = Uncertainty of Validation

- The Uncertainty in Validation (U_{VAL}), also referred to as the experimental uncertainty, has up to 3 input variables for the Calculated Dose Approach:
 - U_{IN} = Uncertainty of interpolation
 - U_S = Uncertainty of sensor value
 - U_{DR} = Uncertainty of the fit of the dose-response-curve

Alternative Validation Protocols

5.2.2 Alternative Validation Protocols

The Austrian Standards *ÖNORM M 5873-1* and *M 5873-2* (2001 and 2003, respectively) and the German Guideline DVGW W294 (2006) define measured flow rate, UV intensity, and lamp status for a *Bacillus subtilis* RED of 40 mJ/cm². Based on the recommended validation protocol presented in this guidance manual, UV reactors certified by ÖNORM and DVGW for a *B. subtilis* RED of 40 mJ/cm² should be granted 3-log *Cryptosporidium* and 3-log *Giardia* inactivation credit. Validation by *NWRI/AwwaRF Guidelines* and *NSF Standard 55* should be evaluated on a case-by-case basis (NWRI 2003, NSF 2004).

Products for UV Drinking Water Disinfection



Let there be light! - Introduction to USEPA's UVDGM

March 2010

WEDECO

WEDECO BX Example Installation



WEDECO LBX Example Installation



WEDECO K143 Example Installation

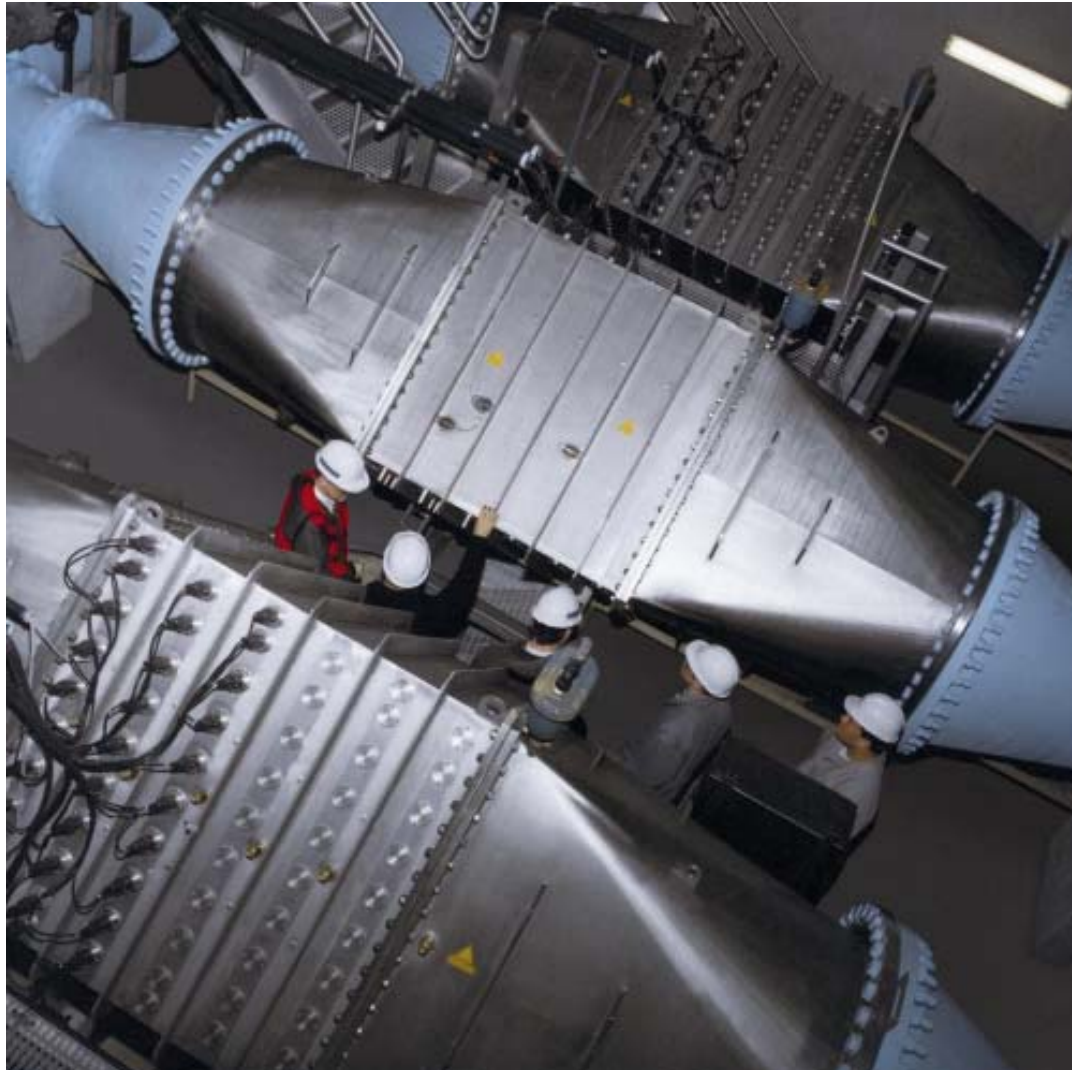

WEDECO Spektron Example Installation



Thank You For Your Attention!

Questions?

